



JSL INDUSTRIES LTD.

“Jyoti” Vertical Hollow Shaft Squirrel Cage Screen Protected Drip Proof Motors

Introduction

Features

Dimensional & Technical Details

General & Dimensional Sketch



Provides protection against dripping liquids and falling objects.

'JYOTI' Vertical Hollow Shaft Squirrel Cage Screen Protected Drip Proof Motors

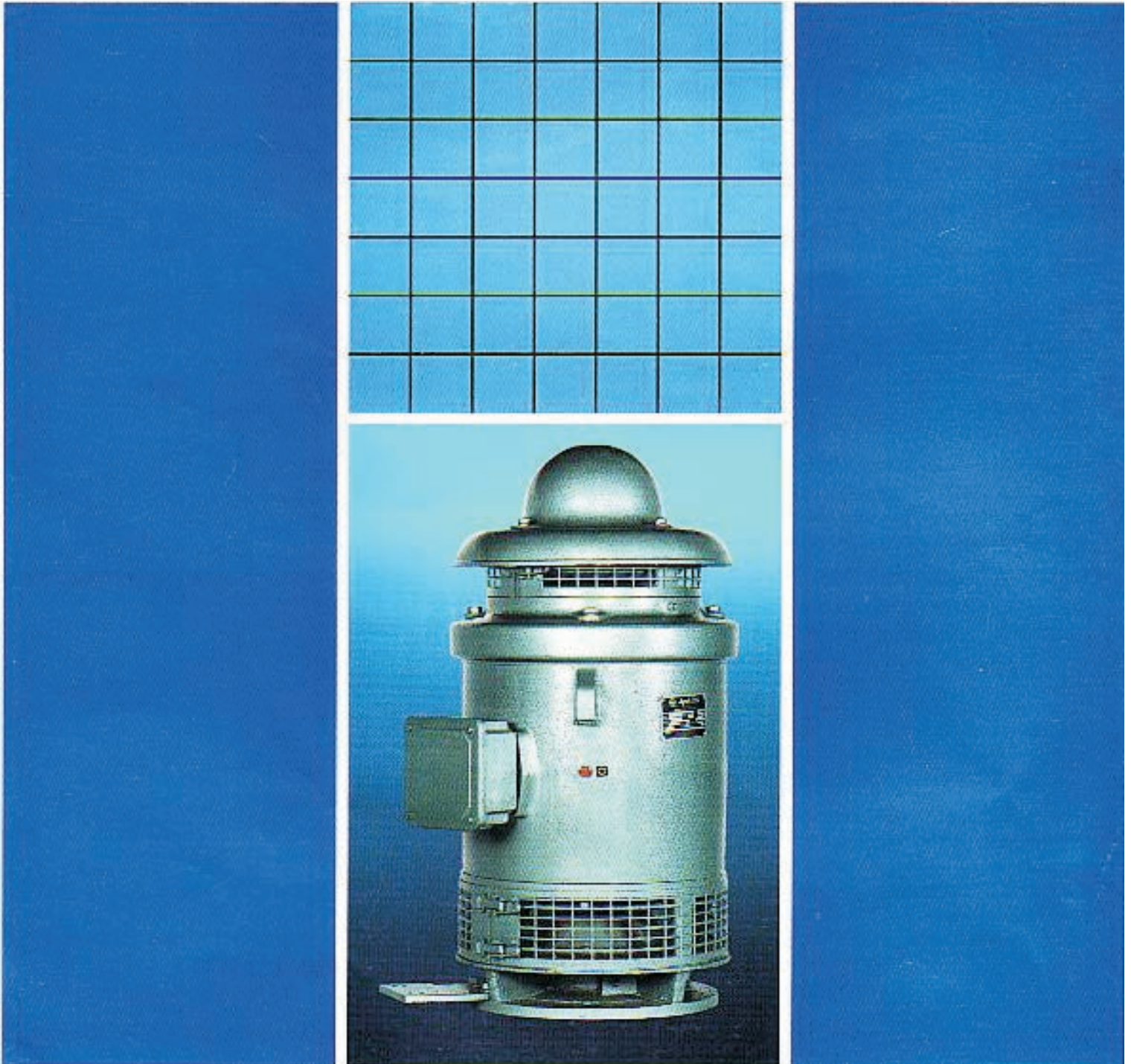

'JYOTI' VERTICAL HOLLOW SHAFT (VHS) MOTORS

These motors find special application in driving Vertical Turbine, Propeller, Mixed and Non-clog Pumps

SPECIFICATIONS

'JYOTI' VHS Motors are continuously rated (S1 duty) as per IS:325 and are suitable to operate on 3-phase 415 V \pm 10% , 50 Hz \pm % electric supply. Combined voltage and frequency variation on load is \pm 10%. The performance generally conforms to IS : 325. The motors are available in ratings upto 45 kW/60 HP, 1500 RPM & 18.5 kW/25 HP, 3000 RPM, in frame size upto 200.

ENCLOSURE AND MOUNTING

Motors are in drip-proof enclosure having degree of protection IP-22 as per 4691. Top cover dome and metallic screen are specially designed to give protection against dripping liquids and falling objects. It also prevents any possibility of accidental touch to moving parts by the operators. Mounting flange dimensions of these motors are in accordance with IS-2254.

The rigid construction of body and covers offers very good mechanical strength to spigots and bearing housing for assembly and dismantling of motors.

STATOR / ROTOR STACKS

Stator and rotor stacks are made of low-loss silicon steel laminated stampings to minimise iron losses.

The Stator stack is held in position by stacking ribs in motor body to ensure uniform air-gap and to minimise

Rotor stampings are directly stacked on precisely machined carbon steel shaft. The rotors are aluminium die-cast. All rotors are finished to close tolerances and dynamically balanced on highly accurate electronic balancing machine.

WINDING AND INSULATION

Stator winding is of Polyester Super Enamelled copper wires conforming to IS:13730, Part-III. The overhangs of the windings are well shaped and rigidly braced to withstand high stresses developed during starting of the motor. Class 'F' insulating materials with temperature rise limited to 'B' are used as insulation to provide electrical, thermal and mechanical strength to the windings. The temperature rise is limited to 75°C over the ambient temperature of 45°C.

Stator windings are impregnated under vacuum & pressure with thermosetting varnish. This ensures very good penetration of varnish into the windings and offers better heat transfer, mechanical strength and protection against moisture. Additional coating of air drying varnish is given when motors are required to operate under very high humid atmosphere.

BEARINGS

Carefully selected angular contact. Heavy duty bearings are located at the top to take the thrust load and deep groove ball bearing is used at the bottom of the motor. The floating arrangement at the bottom bearing ensures safety of these bearings against possible damage due to imposition of thrust load and axial expansion of shaft. Ball bearings are greased with lithium base grease grade-3 having a drop point of more than 160°C. Well designed lubrication arrangement is provided for both top and bottom bearings.

VENTILATION

The optimum cooling is effected by guided air flow generated by rotor fins/fan. The cooled air is taken in from the top and the hot air is expelled out from the bottom. The air openings are well protected by properly sized screen.

NON-REVERSIBLE RATCHET

It is essential for the vertical turbine pump that the direction of rotation is fixed. Otherwise line shaft may get unscrewed, thus damaging the pump. To ensure proper direction of rotation, a non-reversible ratchet is provided in all the motors. The standard direction of rotation of motor is anticlockwise looking from the top. However, motors running in clockwise direction also can be given on request. For this non reverse ratchet has to be replaced.

COUPLING

An easily accessible coupling located at the top of the motor facilitates coupling of pump and motor as well as permits vertical adjustment of the impellers in the pump through head shaft.

TERMINALS AND TERMINAL BOX

Six terminals made from extruded brass/copper rod and having adequate current carrying capacity are provided for either star-delta or auto transformer starting. Delta links are provided if required for direct-on-line starting. Terminal Box has ample space if required for easy terminal connections. Cable entry can be arranged from any direction in steps of 90°.

EARTHING

2 Nos. earthing bolts are provided for earthing connection at diametrically opposite connection.

LIFTING HOOKS

Two lifting hooks of adequate capacity are provided at diametrically opposite location to lift the motor for carrying out installation, alignment, repairs and overhauling.

TEST

All the motors are tested during manufacturing and before despatch, in accordance with IS:325. In case motors are required for wider voltage variations for operating at different voltage, the same can be offered on request.

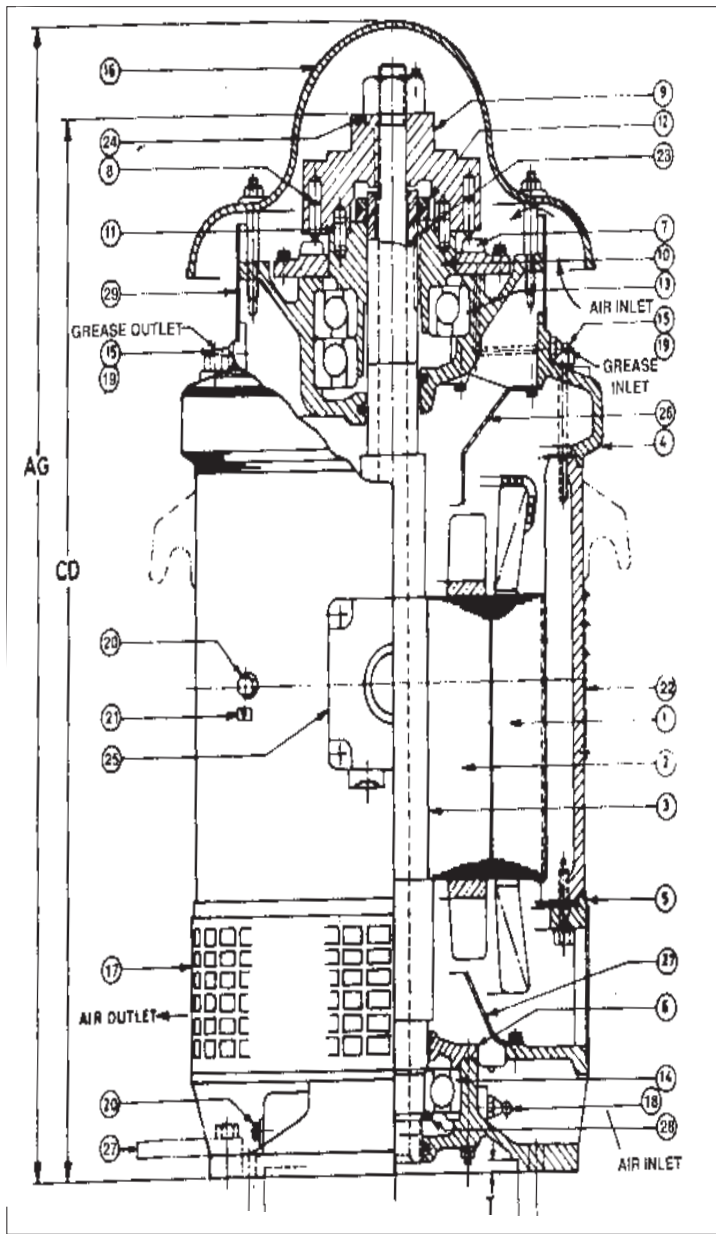

MOTOR FRAME	POLE	RATED OUTPUT kW	TOP BRG TYPE SKF OR EQU	BOTTOM BRG TYPE SKF OR EQU
CVD-132-B	2	3.7	2 x 7309 45 x 100 x 25	6308 35 x 80 x 21
CVD-132-B	4	3.7	2 x 7309 45 x 100 x 25	6308 35 x 80 x 21
CVD-160-B1	2	7.5	2 x 7310 50 x 110 x 27	6308 40 x 90 x 23
CVD-160-B1	2	9.3	2 x 7310 50 x 110 x 27	6308 40 x 90 x 23
CVD-160-B1	2	11	2 x 7310 50 x 110 x 27	6308 40 x 90 x 23
CVD-160-B1	4	5.5	2 x 7310 50 x 110 x 27	6308 40 x 90 x 23
CVD-160-B1	4	7.5	2 x 7310 50 x 110 x 27	6308 40 x 90 x 23
CVD-160-B2	2	13	2 x 7312 60 x 130 x 31	6310 50 x 110 x 27
CVD-160-B2	2	15	2 x 7312 60 x 130 x 31	6310 50 x 110 x 27
CVD-160-B2	4	9.3	2 x 7312 60 x 130 x 31	6310 50 x 110 x 27
CVD-160-B2	4	11	2 x 7312 60 x 130 x 31	6310 50 x 110 x 27
CVD-160-B2	4	13	2 x 7312 60 x 130 x 31	6310 50 x 110 x 27
CVD-160-B2	4	15	2 x 7312 60 x 130 x 31	6310 50 x 110 x 27
CVD-160-B2	4	17	2 x 7312 60 x 130 x 31	6310 50 x 110 x 27
CVD-160-B2	4	18.5	2 x 7312 60 x 130 x 31	6310 50 x 110 x 27
CVD-180-B	4	22	2 x 7316 80 x 170 x 39	6311 55 x 120 x 29
CVD-180-B	4	26	2 x 7316 80 x 170 x 39	6311 55 x 120 x 29
CVD-200-B1	4	30	2 x 7316 80 x 170 x 39	6211 55 x 100 x 21
CVD-200-B1	4	33.5	2 x 7316 80 x 170 x 39	6211 55 x 100 x 21
CVD-200-B1	4	37	2 x 7316 80 x 170 x 39	6211 55 x 100 x 21
CVD-200-B2	4	45	2 x 7316 80 x 170 x 39	6211 55 x 100 x 21
CVD-200-B1	4	33.5	2 x 7316 80 x 170 x 39	6211 55 x 100 x 21
CVD-225-B	4	54.4 to 60	7320B 100 x 215x47	6212 60 x 110 x 22
CVD-250-B	4	67.5 to 93	7322B 100 x 240 x50	6316 55 x 100 x 21

SR.NO	PART NAME	SPECIFICATION
1	STATOR ASSEMBLY	---
2	ROTOR ASSEMBLY	---
3	ROTOR SHAFT	BLACK BAR 40-C8 IS:7283
4	TOP COVER	CAST IRON As per IS :210
5	BOTTOM COVER	CAST IRON As per IS :210
6	BTM. BRG. COVER	CAST IRON As per IS :210
7	RATCHET	CAST IRON As per IS :210
8	RATCHET PIN	BLACK BAR 40-C8 IS:7283
9	SAFETY CLUTCH TOP HALF	CAST IRON
10	SAFETY CLUTCH BOTTOM HALF	CAST IRON
11	SAFETY CLUTCH PIN	BLACK BAR 40-C8 IS:7283
12	RT SHAFT TOP LOCKNUT	BLACK BAR 40-C8 IS:7283
13	TOP BEARING	---
14	BOTTOM BEARING	---
15	GREASE PIPE	GALV. STEEL IS :1239

SR.NO	PART NAME	SPECIFICATION
16	SHELTER DOME	CAST ALU/CAST IRON
17	BTM.PROT.GRILL ASSLY.	-
18	GREASE NIPPLE (AM 10x1)	IS: 4009 P-II
19	GREASE PLUG(10)	IS: 1239
20	EARTHING WIRE SCREWS (HEX) (GALV.ZINC PLATED)	4-G IS:1363 P-2
21	EARTHING SYMBOL	SELF ADHESIVE TYPE PVC LABLE
22	NAME PLATE	ALUMINIUM SHEET
23	KEY FOR BTM.HALF CLUTCH	BLACK BAR SQ.40-C8 IS:7283
24	KEY FOR TOP.HALF CLUTCH	BLACK BAR SQ.40-C8 IS:7283
25	TERM. BOX. ASSLY.	-
26	TOP & BTM. AIR GUIDE	ST. SHEET D.D. IS : 513
27	OIL LUBRICATION FIXING PLATE	ISPL IS : 26
28	BTM. BRG. CIRCLIP	IS : 3075
29	TOP PROT. GRILL ASLY.	-

FRAME	P+	N H8	M P.C.D	T	TX+	CD	AG+	D+	BV-	S 0	AB+	AC	AF-	CxI	KEY	O THRDS	XB	XF	XD	BZ
CVD-132 B	255	209.55	232	6	15	438	505	282	192	11.2	208	168	62	24H8 -	8X7 -	M5 -	37	34	5.5	17.5 -
CVD-160 B1	255	209.55	232	6	18	514	580	340	220	11.2	232	192	72	24H8 -	8X7 -	M5 -	65	38	5	18.5 -
CVD-160 B2	305	209.55	232	6	15	660	715	350	310	11.2	237	197	72	24H8 -	8X7 -	M5 -	73	45	6	18.5 -
CVD-180 B	420	342.90	375	6	18	692	780	425	304	18	295	232	72	33H8* 24H8	10X8 8X7	M5 M5	86	57	6	22 17.5
CVD-200B1	420	342.90	375	6	20	780	865	460	345	18	325	272	105	33H8* 24H8	10X8 8X7	M5 M5	95	60	6	22 18.5
CVD-200B2	420	342.90	375	6	20	846	935	460	378	18	325	272	105	33H8* 24H8	10X8 8X7	M5 M5	95	60	6	22 18.5
CVD-225B	420	342.90	375	8	20	849	963	525	375	18	367	305	130	39H8*	14X9	M8	96	65	6	35
CVD-250-B	510	342.90	375	8	20	949	1040	550	409	18	375	315	130	33H8 38H8 39H8 42H8 50H8	10X8 12x8 12x8 12x8 14x8	M5 M5 M5 M5 M8	110	75	6	22 27 27 27 35

- 1) ALL DIMENSIONS ARE IN mm EXCEPT OTHERWISE STATED.
- 2) I DIMENSION 'BX' INDICATE THE MAXIMUM HEAD SHAFT DIA. PERMITTED FOR EACH FRAME
- 3) * STD 'BX' AND CORRESPONDING CLUTCH DIMENSIONS. IF OTHER THAN STD. CUSTOMER TO SPECIFY
- 4) + SHALL NOT EXCEED BY 5 mm.
- 5) - APPROXIMATELY

GENERAL DIMENSIONAL SKETCH OF 'JYOTI' SQUIRREL CAGE SCREEN PROTECTED DRIP PROOF VERTICAL HOLLOW SHAFT MOTOR.

PUMP SHAFT
NUT & LOCKING SCREWS
ARE NOT FURNISHED
WITH MOTOR

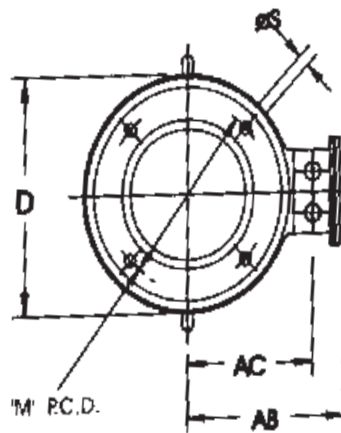
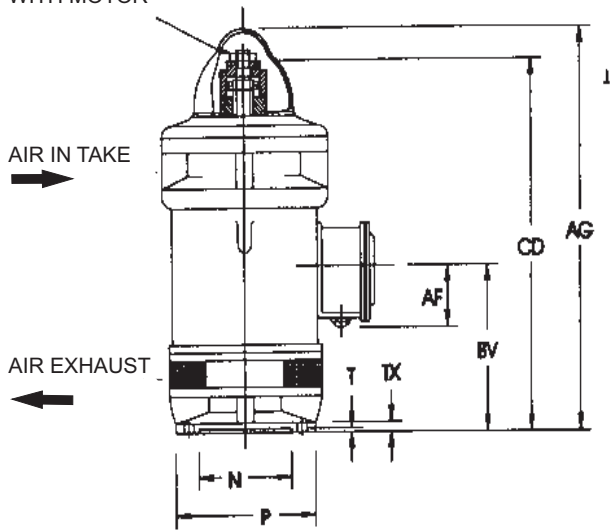

VIEW FROM BOTTOM

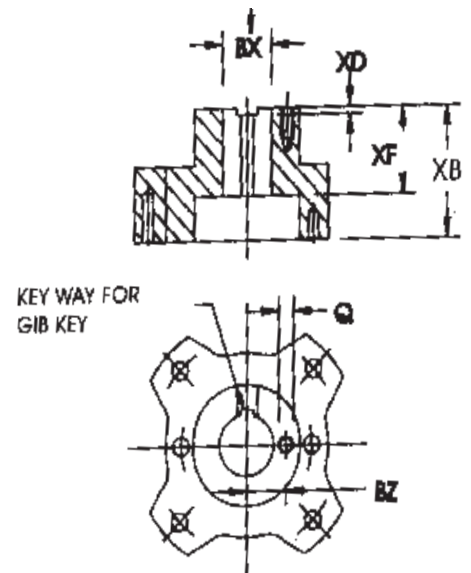

SAFETY CLUTCH TOP HALF