



'Jyoti'
Solid State
Instantaneous /
Definite Time Lag
Under/Over Voltage
Relays (Type PV / SPVK)

- Compact in size to save space and cost
- In-built characteristics ensure superior performance



SALIENT FEATURES

- CONTINUOUSLY ADJUSTABLE RANGE
- VERY HIGH DROP OFF/PICK UP RATIO
- POSITIVE OPERATION WITHOUT CHATTER
- AVAILABLE WITH WIDE RANGE OF TIME DELAY UNIT IN THE SAME CASE
- UN-AFFECTED BY NORMAL VARIATION IN FREQUENCY OF INPUT VOLTAGE

APPLICATIONS

- OVER VOLTAGE PROTECTION OF GENERATORS, POWER CAPACITORS, ETC.
- UNDER VOLTAGE PROTECTION OF AC MOTORS.
- AUTOMATIC VOLTAGE CHANGE OVER SCHEMES.

GENERAL DESCRIPTION

The PV/SPVK relay consists of a MAIN CARD and a POWER SUPPLY CARD.

PV relays are instantaneous and SPVK relays are with definite time delay element.

Type PV relay comprises of a static voltage measuring element having high accuracy and an auxiliary relay type RE-300 with hand reset Electronic (LED) flag indicator for trip.

Type SPVK relay comprises of a static voltage measuring element and static time delay element with hand reset Electronic (LED) flag indicator.

MAIN CARD

This card basically consists of Voltage measuring circuit, Time delay circuit, Auxiliary relay driving circuit and Flag circuit.

STATIC VOLTAGE MEASURING ELEMENT

This consists of a sensing transformer for an input signal. The stepped down and filtered signal is rectified by an absolute value precision rectifier (full wave), which is again filtered and buffered by using an operational amplifier circuits. This signal is compared with the reference voltage by using voltage comparator circuit. The voltage setting is continuously adjustable by setting potentiometer. The output of the

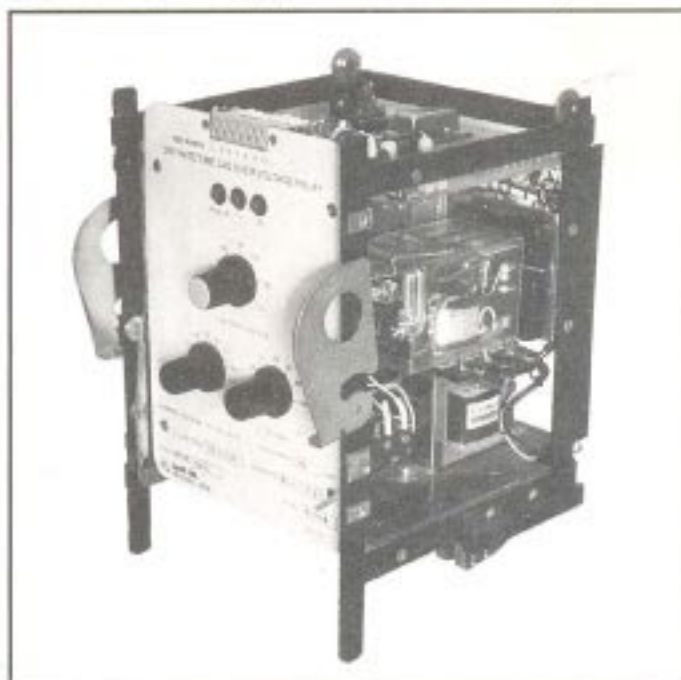

comparator circuit initiates the time delay element in the SPVK relay whereas in PV relay it operates instantaneously.

STATIC TIME DELAY ELEMENT

This element works on the principle of current charging of capacitor having high accuracy, better repeatability, wide range and low burden. The timer is initiated by active low signal output of static voltage measuring element, which initiates the charging of a capacitor through an appropriately selected resistor. At the end of the set time delay, the voltage across the capacitor overcomes the bias of level detector circuit to operate the auxiliary output relay. The time delay is varied by changing the value of the resistor in R-C network, using both step and fine control dial knobs. This element is not used in PV relay.

AUXILIARY RELAY DRIVING CIRCUIT

This circuit is designed so as to meet the requirement of operating time and reset time. Reed relay driven by the operational amplifier output is used to drive the auxiliary output relay.

FLAG CIRCUIT

There are three Electronic flags (LED) provided on the front plate for pick-up, Auxiliary DC healthy condition and trip condition. Trip flag is of hand reset type.

POWER SUPPLY CARD

The power supply block gives appropriate and highly stabilized DC bias voltage to the relay circuit. The relay is protected from the high voltage spikes and accidental reverse polarity connection of DC auxiliary supply.

The test points are provided on the front plate of the relay, which will help in checking the healthiness of the relay circuit.

TECHNICAL PARTICULARS

VOLTAGE RANGE

This relay is available with two types of voltage ranges.

| | | |
|---------------------|---|---|
| OVER VOLTAGE RELAY | : | Continuously adjustable 110% - 140% of nominal voltage (110 VAC). |
| | | and |
| | | Continuously adjustable 110% - 170% of nominal voltage (110 VAC) |
| UNDER VOLTAGE RELAY | : | Continuously adjustable 40% - 80% of nominal voltage (110 VAC) |
| | | and |
| | | Continuously adjustable 30% - 90% of nominal voltage (110 VAC) |

B. VOLTAGE RANGE (FIX)

| | | |
|---------------------|---|---|
| OVER VOLTAGE RELAY | : | Any voltage between 110% to 170% of the nominal voltage (110 VAC) |
| UNDER VOLTAGE RELAY | : | Any voltage between 20% to 90% of the nominal voltage (110 VAC) |

OPERATING TIME OF PV RELAY

OVER VOLTAGE RELAY : Less than 60 msec. at 110% of setting value.

UNDER VOLTAGE RELAY : Less than 60 msec. when voltage falls below the 80% of the setting value.

OPERATING TIME OF SPVK RELAY

SPVK relays are available with extremely wide operating time range from 50 msec. to 120 secs. This range is divided in seven basic steps viz. 1,2,6,10,20,60 & 120 secs.

All of the above ranges are available with Time Multiplier continuously variable between 0.05 to 1.

Resetting time of the relay is less than 200 msec.

ACCURACY

A. VOLTAGE RANGE

UNDER VOLTAGE RELAY (FIX OR VARIABLE) :

The operating value of the relay conforms to the accuracy of $\pm 5\%$ of the setting value. The reset value of the relay is equal to or less than 110% of setting.

OVER VOLTAGE RELAY (FIX OR VARIABLE) :

The operating value of the relay conforms to the accuracy of $\pm 5\%$ of the setting value. The reset value of the relay is equal to or more than 90% of the setting.

B. OPERATING TIME RANGE

Basic accuracy $\pm 5\%$ of the set time or ± 10 msec., whichever is greater at rated voltage and at ambient temperature range of 10°C to 40°C .

Basic accuracy $\pm 10\%$ of the set time or ± 20 msec., whichever is greater at rated voltage and at ambient temperature range of 0°C to 60°C .

REPEAT ACCURACY

1% or 10 msec. whichever is greater when allowed to reset for about five times the set time.

DC BURDEN

THERMAL RATING

Over voltage relay : The over voltage unit can withstand 150% of the setting voltage continuously.

Under voltage relay : The under voltage unit can withstand three times the minimum voltage continuously.

AUXILIARY SUPPLY VOLTAGES

Standard Voltages : DC 24V, 30V, 50V, 110V & 220V.

Relays suitable for other DC voltages can be supplied on request. The relay works satisfactorily over a range 80% to 110% of the rated auxiliary voltage.

OUTPUT CONTACTS

Self reset type with following rating.

Make and carry continuously : 1250VA with a maxima of 660V and 5 Amps.

Make and carry for 3 seconds : 7500 VA with a maxima of 660V and 30 Amps.

Break rating :

AC : 1250VA with a maxima of 660 V and 5 Amps; with a minimum P.F. of 0.4

D C : 100 watts (Resistive) with a maxima of 220V and 5 Amps and 50 watts (Inductive) with a maxima of 220V and 5 Amps; and maximum time constant 45 msec.

INSULATION TEST

The relay shall withstand 2KV AC, RMS, 50Hz for one minute between all terminals connected together and all the metallic parts intended to be earthed.

The relay shall withstand 1 KV AC, RMS, 50Hz for one minute between normally open output contacts in open position.

OPERATION INDICATOR

The relay is provided with a hand reset type LED operation indicator. It can be resettled from outside without opening relay cover.

CASE

The relays are supplied as a single pole element in 1D draw-out casing. It is suitable for flush mounting.

This draw-out casing has contact strips in which spring loaded shorting link is provided where NC Contacts are given. This will automatically short circuit the NC contacts when the relay is withdrawn from the casing. This facilitates removal of the relay for testing, inspection, etc. without disturbing the external connection.

INFORMATION REQUIRED WITH ORDER

- Type of relay : a) Under voltage or Over voltage.
b) Instantaneous or with Definite time lag (PV or SPVK)
c) % Voltage setting range (Fixed or Variable)

2. DC Auxiliary voltage.

| TYPE | CONDITION | BURDEN IN WATTS AT AUXILIARY DC SUPPLY VOLTAGE | | | | |
|--|------------|---|------|-----|-----|-----|
| | | 220V | 110V | 50V | 30V | 24V |
| SPVK UNDER / OVER VOLTAGE OR PV OVER VOLTAGE | CONTINUOUS | 8.5 | 5.0 | 2.5 | 1.5 | 1.0 |
| | HOLD ON | 9.5 | 5.5 | 2.5 | 1.5 | 1.0 |
| | TRANSIENT | 19.5 | 11.0 | 7.5 | 6.0 | 5.5 |
| PV UNDER VOLTAGE | CONTINUOUS | 15.5 | 9.0 | 6.5 | 5.0 | 5.0 |
| | HOLD ON | 16.5 | 9.5 | 7.0 | 5.5 | 5.0 |
| | TRANSIENT | 30.0 | 5.5 | 2.5 | 1.5 | 1.0 |

**SCHEMATIC DIAGRAM FOR PV UNDER / OVER VOLTAGE
RELAY (FIX OR VARIABLE) DROWOUT TYPE**

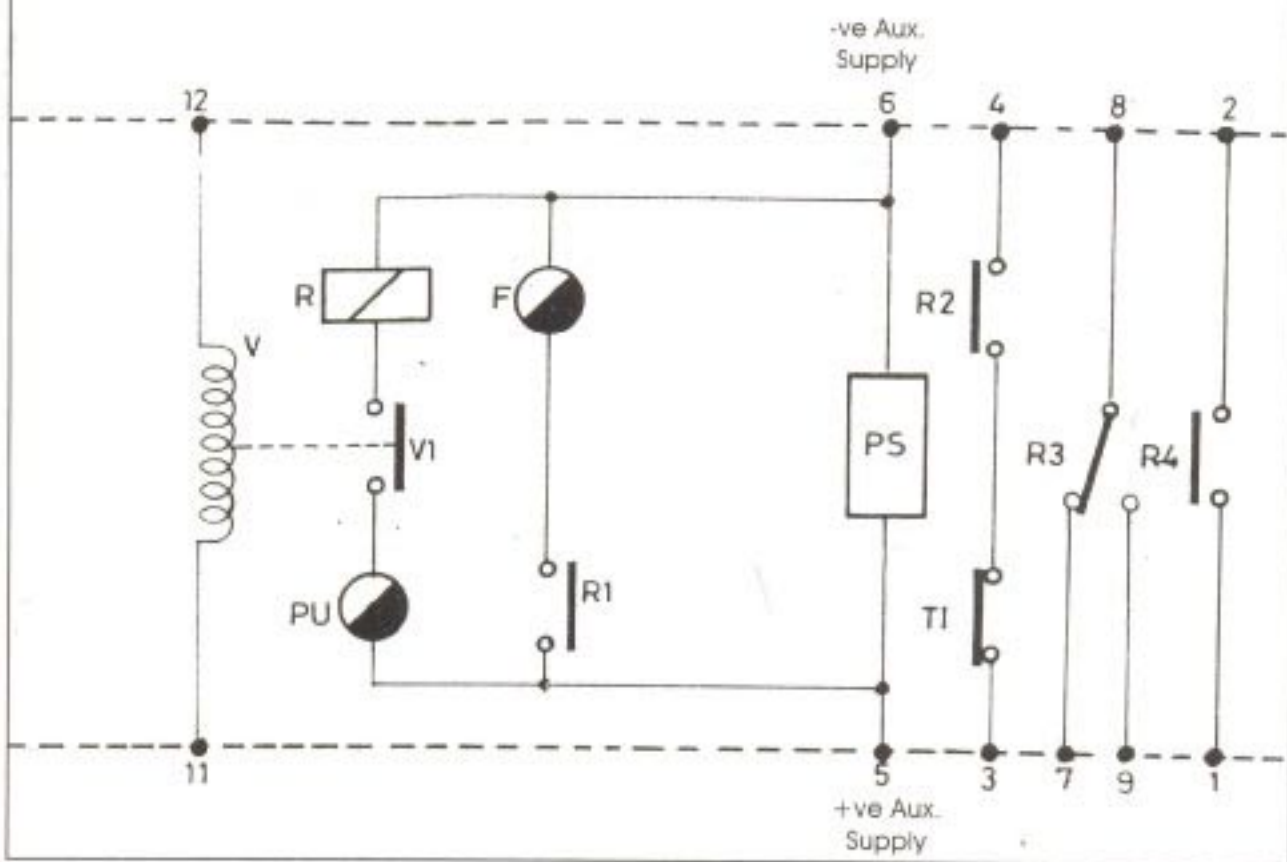

- V - UNDER VOLTAGE OR OVER VOLTAGE SENSING UNIT
- PU - RELAY PICK UP INDICATION (LED)
- D - TIME DELAY UNIT
- V1 - OUTPUT OF UNDER VOLTAGE / OVER VOLTAGE SENSING UNIT
- PS - POWER SUPPLY

- D1 - OUT PUT OF TIME DELAY UNIT
- R - OUT PUT AUXILIARY RELAY (RE - 300)
- F - TRIP INDICATION (LED, HAND RESET)
- T1 - TRIP ISOLATION
- R1 - } OUT PUT CONTACTS OF RE - 300
- R2 - }
- R3 - }
- R4 - }

| RELAY TYPE | CONTACTS | RELAY CONTACTS | | |
|------------------|-------------|--|--|--|
| | | TERMINAL NO. 1 & 2 RE CONTACT R4 | TERMINAL NO. 3 & 4 RE CONTACT R2 | TERMINAL NO. 7,8,9 RE CONTACT R3 |
| PV OVER VOLTAGE | 2 NO + 1 CO | NO | NO | CO |
| PV UNDER VOLTAGE | 2 NC + 1 CO | NC | NC | CO |

NOTE : CONTACTS ARE SHOWN IN POWER OFF CONDITION

**SCHEMATIC DIAGRAM FOR SPVK UNDER / OVER VOLTAGE
RELAY (FIX OR VARIABLE) DROWOUT TYPE**

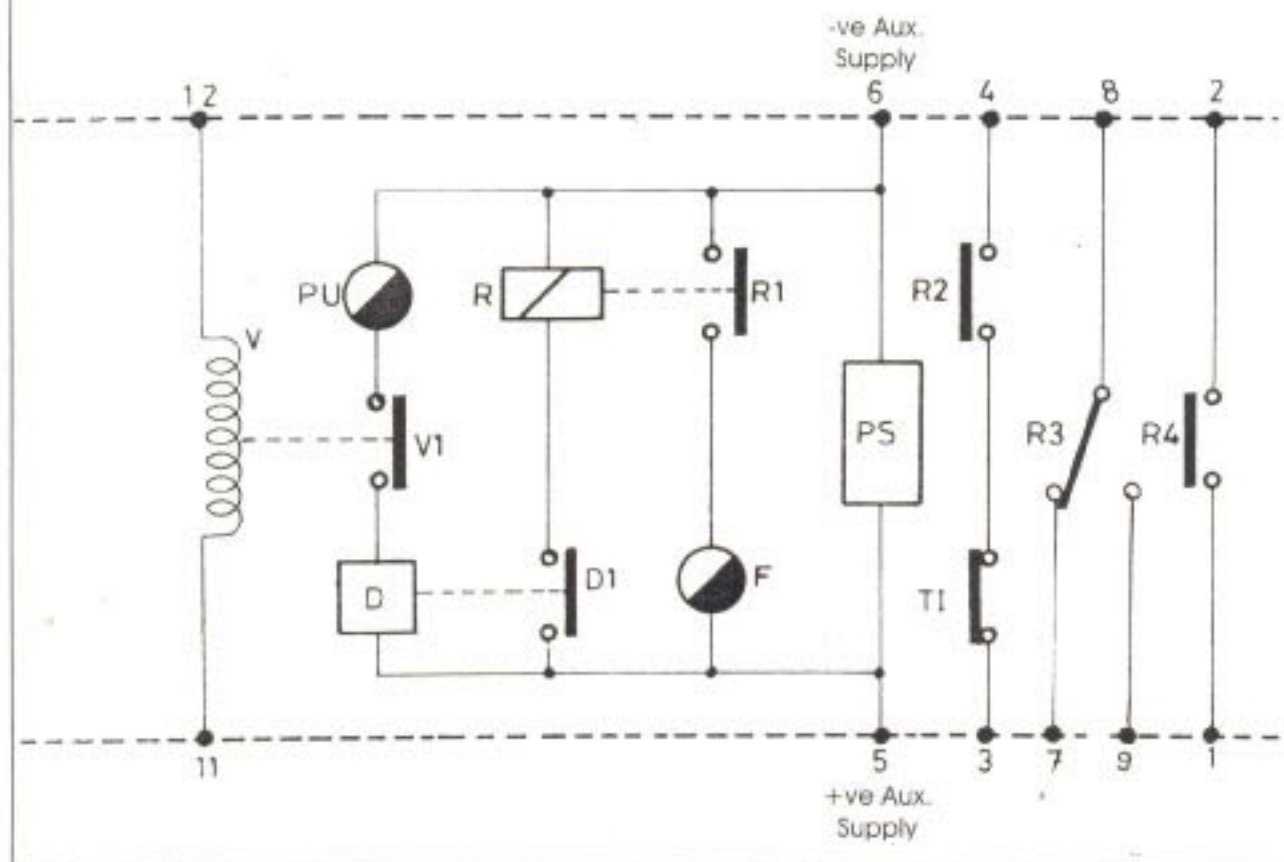

- | | |
|--|--|
| V - UNDER VOLTAGE OR OVER VOLTAGE SENSING UNIT | D1 - OUT PUT OF TIME DELAY UNIT |
| PU - RELAY PICK UP INDICATION (LED) | R - OUT PUT AUXILIARY RELAY (RE - 300) |
| D - TIME DELAY UNIT | F - TRIP INDICATION (LED, HAND RESET) |
| V1 - OUTPUT OF UNDER VOLTAGE / OVER VOLTAGE SENSING UNIT | T1 - TRIP ISOLATION |
| PS - POWER SUPPLY | R1 - } OUT PUT CONTACTS OF RE - 300 |
| | R2 - } |
| | R3 - } |
| | R4 - } |

| RELAY TYPE | CONTACTS | RELAY CONTACTS | | |
|----------------------------|-------------|---|---|---|
| | | TERMINAL NO. 1 & 2 RE CONTACT R 4 | TERMINAL NO. 3 & 4 RE CONTACT R 2 | TERMINAL NO. 7,8,9 RE CONTACT R 3 |
| SPVK UNDER/OVER VOLTAGE | 2 NO + 1 CO | NO | NO | CO |

NOTE : CONTACTS ARE SHOWN IN POWER OFF CONDITION

1JD CASING DIMENSION

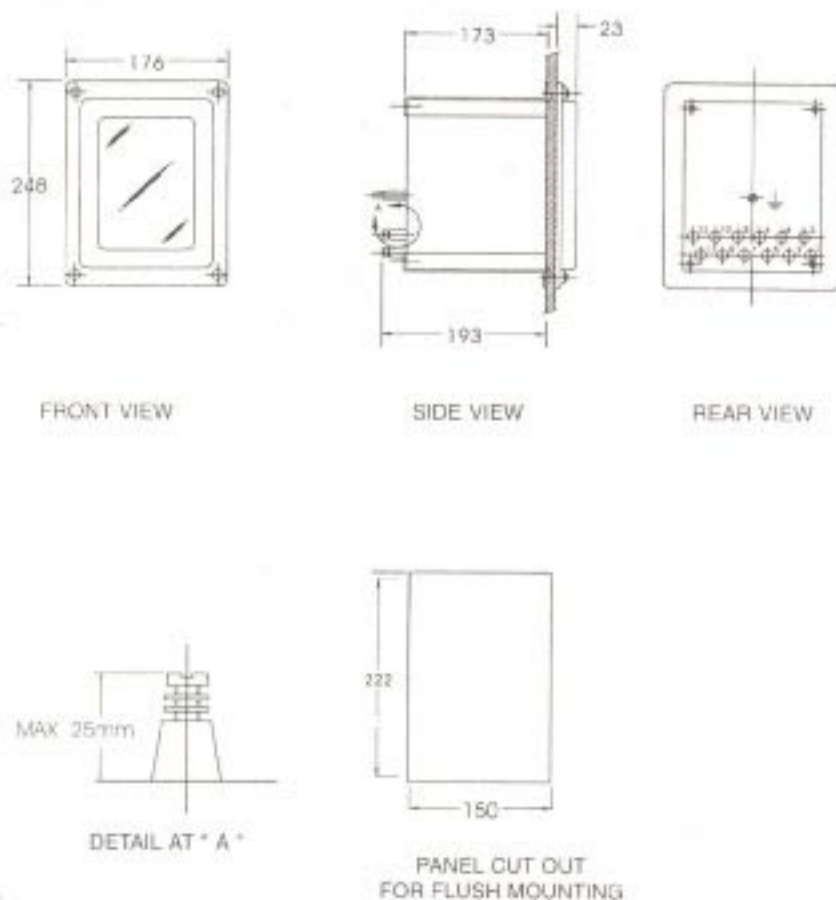

Jyoti Ltd. VADODARA (INDIA)
50 Years of Engineering Excellence

FOR FURTHER ENQUIRIES
PLEASE CONTACT

**Electronics & Control Systems
Division**
3-15, B.I.D.C. Gorwa,
Vadodara-390 016.

Telephones : (0265) 380561,
Tele Fax : +91-265-381214
E-Mail : cmd.jyoti@sm3
sprintpg.ams.vsnl.net.in
Grams : PRO/JYOTI
Website : <http://www.jyoti.com>

ZONAL AND BRANCH
OFFICES

• **Bangalore** : 491, 1st Floor, 10th Cross, 6th Main Sadashivanagar,
Bangalore-500 080. Fax : 080-3313375. E-Mail : kar.jyoti@
sm3.sprintpg.ams.vsnl.net.in • **Calcutta** : 45, Jhowtala Road, Syed
Amr Ali Avenue, Calcutta-700 019, Fax : 033-2475267. E-Mail :
cal.jyoti@sm3.sprintpg.ams.vsnl.net.in • **Chennai** : VEE DEE YEM
Complex, 270, Ground Floor, Loyds Road (Arvai Shanmugham Salai)
Royapettah, Chennai 600014, Fax : 040-8275140. E-Mail : mad.
jyoti@sm3.sprintpg.ams.vsnl.net.in • **Mumbai** : 103, Kakad
Chambers, 132, Dr. Annie Besant Road, Worli, Mumbai-400 018. Fax :
022-4964668. E-Mail : bdy.jyoti@sm3.sprintpg.ams.vsnl.net.in • **New
Delhi** : 406, Chiranjiv Towers, 43, Nehru Place, New Delhi-110 019,
Fax : 011-6426225. E-Mail : del.jyoti@sm3.sprintpg.ams.vsnl.net.in •
Secunderabad : 1st Floor, 5-4-187/7, Karbala Maidan, M.G Road,
Secunderabad-500 003. Fax : 040-7933673. E-Mail : sec.jyoti@
sm3.sprintpg.ams.vsnl.net.in

*In Keeping with the technological strides
the world is making in the engineering
field, we introduce changes in the
design of our products. Hence, the
products as actually supplied might
have features varying herefrom.*

*The word 'Jyoti' and 'Jyoti' logo, are the
registered trademarks of Jyoti Ltd.,
Vadodara-390 003.*